

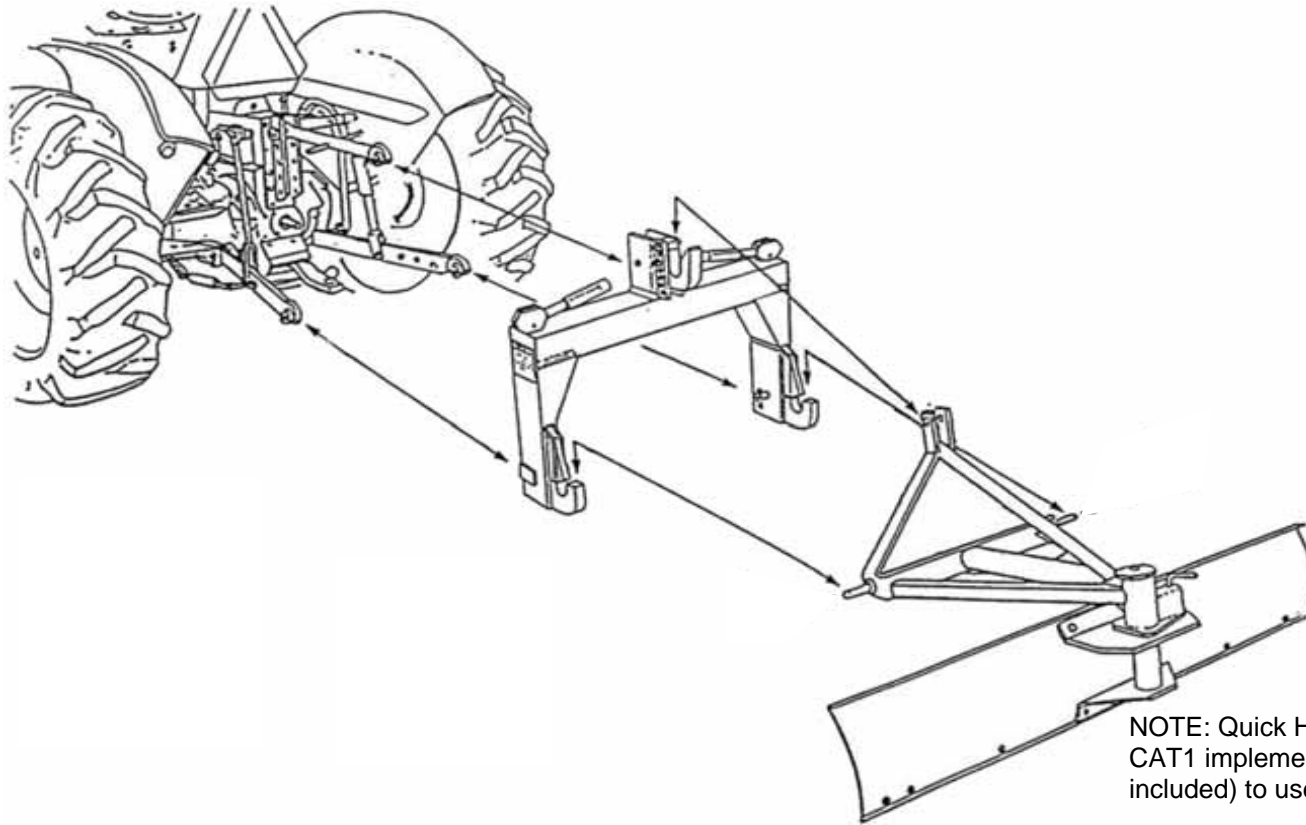

# 3-POINT QUICK HITCH



## Easy Operation

Back Quick Hitch points against implement mounting pins.

Raise tractor 3-point hitch to engage implement draw pins.

Your implement is secured without smashed toes or strained back.

Raise latch handles and reverse this sequence to disconnect.

If lightweight implement is being used, latch handles may have to be raised to properly engage implement.

NOTE: Quick Hitches are made to ASAE Specifications, many CAT1 implements are not and may require an adaptor bracket (not included) to use them with the Quick Hitch.

## Easy Installation Instructions

- 1) Fasten the Quick Hitch to your tractor's lift arms using the solid pins with a flat bracket on one end (provided) and clip pins (included).
- 2) Fasten the tractor's center link to the top bracket of the Quick Hitch using a common top link pin and clip pin (included).
- 3) Install a common top link pin (not provided) on the implement's top framework for the top hook to grab onto.